

**FORD:**

2004-2005 F-150  
2005 Expedition, F-Super Duty

**LINCOLN:**

2005 Navigator

This article supersedes TSB **06-5-9** to update the vehicle lines and model years.

**ISSUE**

Some 2004-2005 F-150 and 2005 F-Super Duty, Expedition, and Navigator vehicles with a 5.4L 3-valve engine may experience difficulty with spark plug removal which may cause damage to the spark plug and leave part of the spark plug in the cylinder head.

**ACTION**

Refer to the following Service Procedure for techniques to remove the spark plugs and extract broken spark plugs.

**SERVICE PROCEDURE****General Spark Plug Removal**

To remove spark plugs without damage, it is necessary to adhere exactly to this procedure before removal is attempted.

1. Make sure the engine is warm (hand touch after cooling down).

**CAUTION**

**DO NOT REMOVE PLUGS WHEN THE ENGINE IS EXTREMELY HOT OR COLD SOAKED. THIS INCREASES THE CHANCE THE THREADS COULD BE DAMAGED.**

**CAUTION**

**BE SURE TO WEAR SAFETY GLASSES FOR STEP 2.**

2. Remove the coil-on-plug assemblies and thoroughly blow out the spark plug wells and surrounding valve cover area with compressed air.

3. Back out the spark plugs, no more than 1/8 to 1/4 of a turn. Apply penetrating oil (AeroKroil or equivalent) and fill the spark plug well just above where the jamb nut hex sits. A minimum period of 5 to 10 minutes of soak time is required. The penetrating oil will wick down to the ground electrode shield in this time. **DO NOT WORK** the spark plug back and forth at this point.

**CAUTION**

**EXCESSIVE PENETRANT, OR REPEATING THE PROCESS SEVERAL TIMES WITH TOO MUCH FLUID, COULD INTRODUCE ENOUGH LIQUID VOLUME TO HYDRO-LOCK THE ENGINE.**

**CAUTION**

**DO NOT USE AIR OR POWER TOOLS FOR PLUG REMOVAL. THE PLUG MUST ONLY BE REMOVED WITH HAND TOOLS.**

4. Slowly turn the spark plug out. Some screeching and high effort may be noticed but, not in every case. The expected removal torque is about 33 lb-ft (45 N•m) but should decrease on the way out. If it is higher, try turning the spark plug back in a half turn, then back out again. If the turning torque still seems high, repeat the back and forth rotation along with some penetrating oil to reduce turning effort.

**Separated/Broken Spark Plug Removal**

If the plug does come apart even after following the General Spark Plug Removal Procedure, it will break in one of two modes:

**Mode 1:** The ground electrode shield is left behind as an empty shell (Figure 1).

**NOTE:** The information in Technical Service Bulletins is intended for use by trained, professional technicians with the knowledge, tools, and equipment to do the job properly and safely. It informs these technicians of conditions that may occur on some vehicles, or provides information that could assist in proper vehicle service. The procedures should not be performed by "do-it-yourselfers". Do not assume that a condition described affects your car or truck. Contact a Ford, Lincoln, or Mercury dealership to determine whether the Bulletin applies to your vehicle. Warranty Policy and Extended Service Plan documentation determine Warranty and/or Extended Service Plan coverage unless stated otherwise in the TSB article. The information in this Technical Service Bulletin (TSB) was current at the time of printing. Ford Motor Company reserves the right to supersede this information with updates. The most recent information is available through Ford Motor Company's on-line technical resources.

## TSB 06-15-2 (Continued)

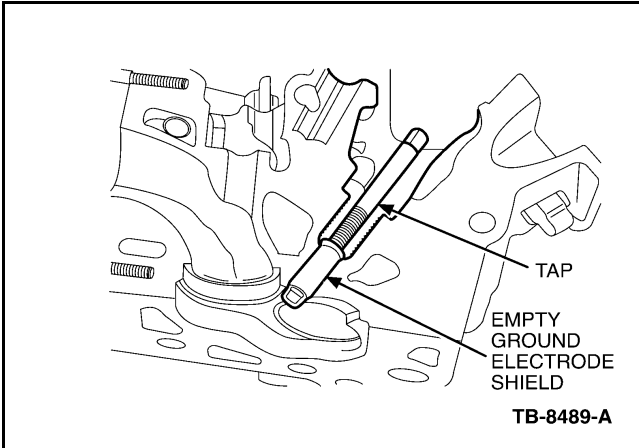

Figure 1 - Article 06-15-2

**Mode 2:** The porcelain center and ground electrode shield is left behind and only the upper jamb nut comes out. In this case more soaking is required and long-reach nose pliers should be used to grasp and remove the porcelain center from the ground electrode shield (Figure 2).

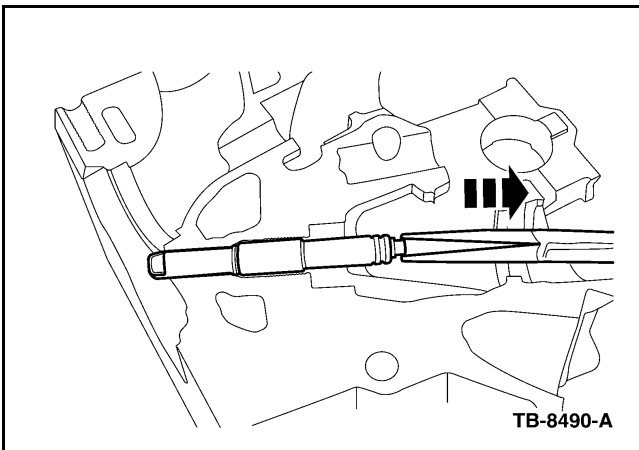

Figure 2 - Article 06-15-2

Once there is only an empty ground electrode shield left in the cylinder head, perform the following steps to remove the shield using Rotunda Special Service Tool 303-1203 (Figure 3).

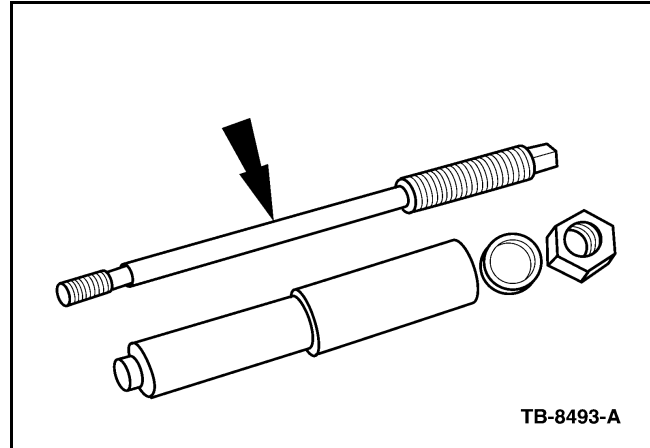

Figure 3 - Article 06-15-2

### **NOTE**

THIS TOOL IS ONLY DESIGNED TO WORK WITH AN EMPTY GROUND ELECTRODE SHIELD. IF THE SPARK PLUG CAME APART IN MODE 2, THE PORCELAIN CENTER MUST BE REMOVED PRIOR TO FOLLOWING THESE STEPS.

1. The combustion chamber must be protected from contamination during the extraction process by using a modified vacuum cap (382444-S) as a stopper-type plug. This is because the remaining ground electrode shield will be thread-tapped, so the cap is needed to prevent thread chips from falling into the cylinder bore. Cut a vacuum cap to a 3/8" (10 mm) length for each ground electrode shield that needs to be removed.
2. Install the modified cap with a long drill bit or suitable wire (Figure 4), sized for the internal diameter of the cap. The rubber cap should bottom-out on the electrode strap of the ground electrode shield once installed.

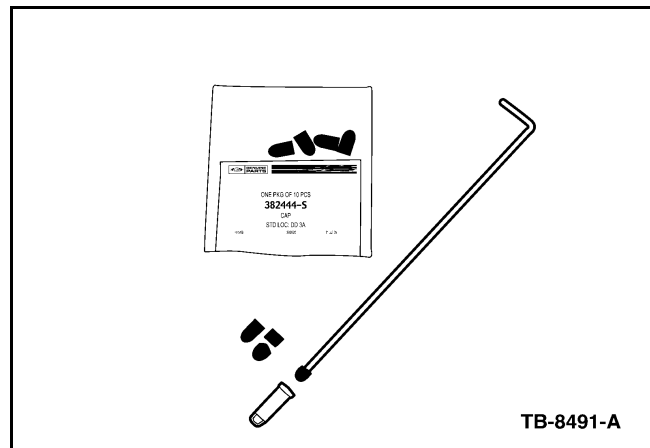

Figure 4 - Article 06-15-2

## TSB 06-15-2 (Continued)

3. Thread-tap the ground electrode shield using a 9.0 x 1.0 mm "plug" tap (tap profile is about 3-4 reduced diameter threads on the tip end).
  - a. Coat the end of the tap with general purpose grease as shown in Figure 5.

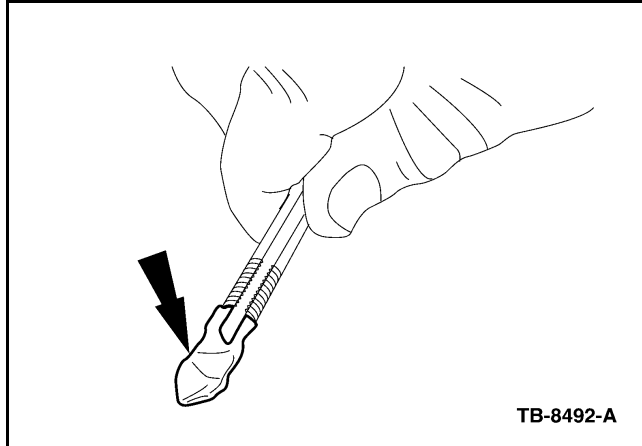

Figure 5 - Article 06-15-2

- b. Turn the tap about 3 to 4 turns into the ground electrode shield once the tap begins to cut. As the shield is tapped, for every 1/2 turn, the tap should be backed up 1/8 turn to "break chips" and prevent any cut material from coiling-up and laying in the spark plug well. All of the thread chips will embed in the grease pack or drop inside the vacuum cap when following this procedure. A suitably sized tap wrench of about 7-9 inches in handle length will aid in reaching down the well. If not available, use an 8 point socket with a ratchet and drive extension. Keep the shank aligned with the axis of the spark plug bore cavity to prevent possible thread bore damage. Use care not to damage any spark plug threads on the way in.

### **CAUTION**

**DO NOT ATTEMPT TO REMOVE THE GROUND ELECTRODE SHIELD WITH THE TAP AND WRENCH. THE TAP MAY BREAK IF THIS IS ATTEMPTED.**

- c. Carefully back out the tap while maintaining the residual grease coat on the tap which contains some chips. Take care not to touch the sides of the spark plug well bore during removal.

4. Once the ground electrode shield is tapped, thread Rotunda Special Service Tool 303-1203 into the ground electrode shield to extract it from the spark plug well and encapsulate any remaining chips from falling into the combustion chamber.

### **NOTE**

SEE FIGURE 6 FOR DETAILS OF THE TOOL AS INSTALLED IN THE HEAD.

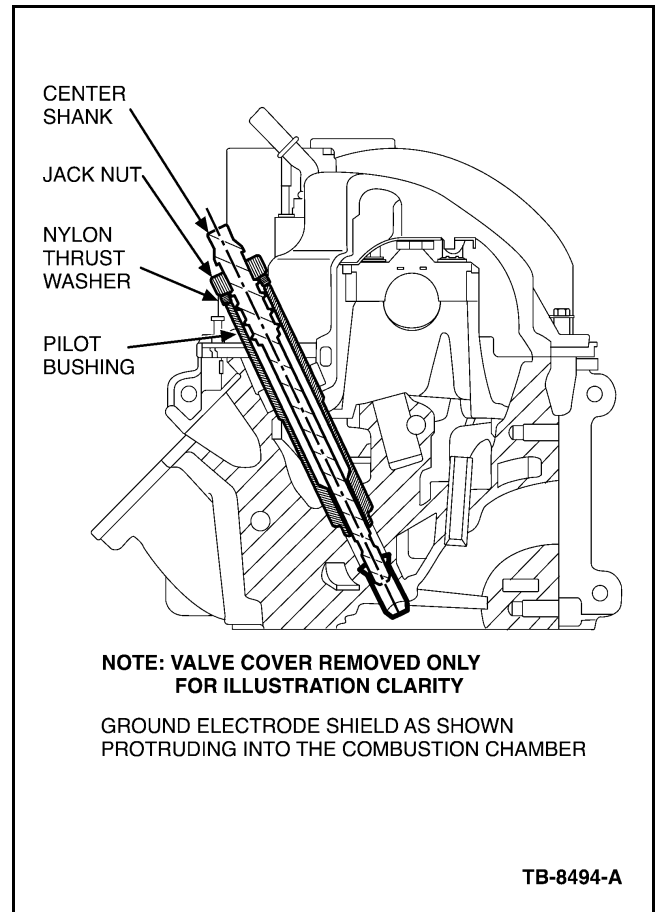

Figure 6 - Article 06-15-2

- a. Install the stepped end of the tool pilot bushing into the spark plug well ensuring it bottoms out.
        - b. Screw the center shank into the ground electrode shield. Do not over tighten the shank, to prevent thread stripping.
        - c. Install the nylon washer and jack nut until finger tight.

## TSB 06-15-2 (Continued)

- d. Turn the jack nut with a socket and 3/8" drive ratchet until the ground electrode is freed from the cavity and withdraw the tool assembly. Several turns of the nut are required. Upon removal, any remaining chips not caught earlier by the tap grease will be captured by the rubber plug sitting at the bottom of the ground electrode shield.

### NOTE

ONCE THE SPARK PLUGS HAVE ALL BEEN REMOVED, NEW PLUGS SHOULD BE INSTALLED USING A FILM COATING OF MOTORCRAFT HIGH TEMPERATURE NICKEL ANTI-SEIZE LUBRICANT (XL-2) ON THE GROUND ELECTRODE SHIELD OF THE NEW SPARK PLUG (FIGURE 7). DO NOT COAT THE ELECTRODE STRAP OR THE PLUG WILL MISFIRE. THE NEW PLUGS SHOULD BE INSTALLED WITH NO LUBRICANT ON THE THREADS AND TORQUED TO SPECIFICATION, 25 LB-FT (34 N•m).

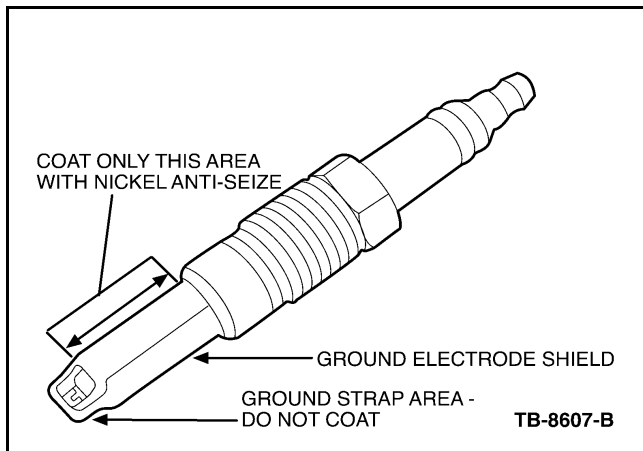

Figure 7 - Article 06-15-2

PART NUMBER	PART NAME
AeroKroil	Obtain through <a href="http://www.kanolabs.com">www.kanolabs.com</a> or by calling 1-800-311-3374 (orange aerosol can)
382444-S XL-2	Vacuum Cap Motorcraft High Temperature Nickel Anti-Seize Lubricant

**WARRANTY STATUS:** Eligible Under Provisions Of New Vehicle Limited Warranty Coverage And Emissions Warranty Coverage

OPERATION	DESCRIPTION	TIME
MT061502	Claim Labor As Actual Time	Actual Time

### DEALER CODING

BASIC PART NO.	CONDITION CODE
12405	01